



FEATURES INCLUDED IN THE 150-S

UPPER BOOM ASSEMBLY

The upper boom assembly is a two-section telescopic type. Two double-acting hydraulic cylinders actuate upper boom/knuckle articulation. Range of articulation is up to 158°.

LOWER COLUMN ASSEMBLY

The lower column is a two-section telescopic type consisting of an inner and outer column. The column is constructed of high strength tubular welded reinforced steel designed to provide maximum strength and rigidity.

MAIN CHASSIS FRAME

The main chassis frame assembly is a torque box frame of ranging from 18 in. (45.72 cm) to 22 in. (55.88 cm) channel rail enclosed top and bottom affording sufficient strength to withstand all torsional and deflection loads imposed by the aerial device.

INSTABILITY WARNING SYSTEM

An audible warning system alerts the operator to a potentially unstable condition in the event outrigger ground pressure is reduced during platform operation.

OUTRIGGERS

The 150 model offers front and rear outriggers swing-out type outriggers. All types provide a generous lateral spread with maximum ground penetration. An outrigger interlock system is included.

CHASSIS ENGINE HYDRAULIC SYSTEM

The A/W/P hydraulic system is closed-center with a variable volume, pressure compensated axial piston pump with flow range from 0 to 35 GPM @ 2,500 PSI. The hydraulic pump is driven by the chassis engine through a power take-off. All hydraulic cylinders are equipped with holding check valves that lock cylinders in a static position in case of hydraulic pressure failure.

TURRET ASSEMBLY

The turret assembly is constructed with welded tubular steel and is affixed directly to the ring gear. The ring gear is internal tooth, ball-type. The turret contains hydraulic-powered worm drive rotation gear and orbit motor, hydraulic pressure gauge, emergency rotation and boom bleed-down and 365° non-continuous rotation.

PLATFORM ASSEMBLY

The work platform is a welded tubular steel structure (96 in. x 36 in. x 43.5 in.) (2.4m x .9m x 1.1m) with an expanded steel floor. The rated platform capacity representing a safe load is not less than 1,000 lbs. (453.5 kg), including all factory-installed options. The platform is equipped with a 180° platform rotation independent of turret rotation. Platform rotation is hydraulically powered.

General Specifications

150-S

Platform Capacity 1000 lbs (453.5 kg)
 Working Height 150 ft 0 in (45.72 m)
 Max. Vertical Platform Height ... 145 ft 0 in (44.19 m)
 Elbow Articulation 158°
 Column Articulation 83°
 Max. Horizontal Reach 71 ft 0 in (21.64 m)

150-S 8x6 Chassis

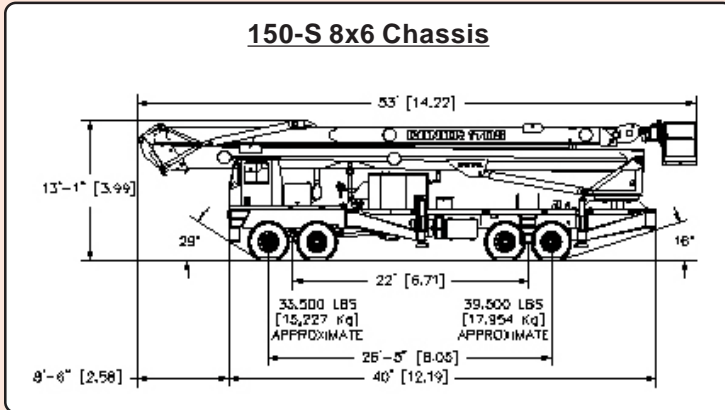

150-S Working Envelope

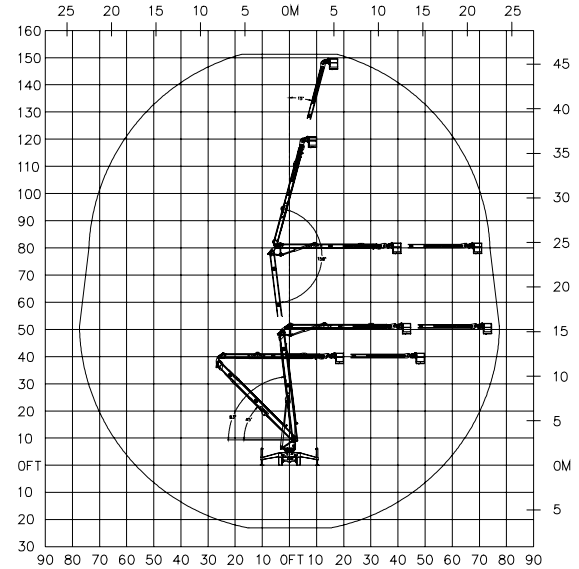

Options

- Material Handling Jib/Hydraulic Winch with Upper/Lower Controls
- Increased Column Articulation
- 2500 PSI Hydraulic Tool Circuit and 10,000 PSI Intensifier
- Aluminum Deck and Wheels
- Aerial Work Platform Engine With Silent Package
- Arctic Climate Package (*Deck and/or Chassis Engine*)
- Tropical Weather Package (*Deck and/or Chassis Engine*)



Offering 150 feet of Working Height