

SKID STEER LOADER



Specifications

Operating Weight	7450 lbs (3379 kg)
Horsepower	74 hp (55 kw)
Height to Bucket Pin	125 in (3175 mm)
Operating Capacity	2000 lbs (907 kg)

Features

- ▶ Radius lift path with rugged loader arms, ready to tackle any job and ideal for digging applications
- ▶ Robust chassis with 10.5" of ground clearance* and a 25.4° angle of departure, able to work on soft, uneven terrain and slopes where other skid steers can't
- ▶ Easy operation with standard pilot-operated joystick controls and comfortable operator station
- ▶ Standard mechanical faced axle seals protect bearings, reducing maintenance and downtime
- ▶ Tilt-up ROPS and tilt-out coolers make daily maintenance checks quick and easy

** Unloaded*

WORKS FOR YOU.™

SPECIFICATIONS

OPERATING SPECIFICATIONS

Loader Arms	Radial
Operating Weight	7450 lbs (3379 kg)
Shipping Weight	6600 lbs (2993 kg)
Tipping Load	3987 lbs (1808 kg)
Rated Operating Capacity	2000 lbs (907 kg)
Operating Capacity (with optional counter weight)	2100 lbs (952 kg)
Maximum Travel Speed	8.5 mph (13.6 kph)
Maximum Travel Speed (with optional 2 speed transmission)	12 mph (19.3 kph)
Height to Bucket Pin	125 in (3175 mm)
Dump Height at Bucket Discharge	95 in (2423 mm)
Dump Reach at Bucket Discharge	20 in (508 mm)
Max Dump Angle at Full Height	46°
Bucket Breakout Force	5500 lbs (2494 kg)
Arm Lifting Force	7000 lbs (3175 kg)
Rear Angle of Departure	26°
Bucket Roll Back at Ground Level	30°
Ground Clearance	
Unloaded	10.5 in (266.7 mm)
Loaded	10 in (254 mm)
Overall Length with Bucket	144 in (3657 mm)

ENGINE

Type	Diesel, 4-Cylinder, Turbocharged
Model	Perkins 804D-33T
Displacement	201 in ³ (3.3 L)
Gross Horsepower @ 2500 rpm	74 hp (55 Kw)
Torque, Peak	180 ft-lb (245 Nm)
Cooling System	Engine-Driven Fan and Coolant/Anti-Freeze Filled Radiator
Engine Block Heater	Standard, AC Plug-In Type
Intake Air Cleaner	Dual Stage
Emissions Controls	Meets All U.S. EPA Interim Tier 3 Standards

DRIVE TRAIN

Drive System	Hydrostatic
Chain Case	Bow Tie Drive System
Chain Size	100 ANSI Chain
Wheel Size	12x16.5
Width Over Tires	72 in (1828 mm)
Tractive Effort	8700 lbs (3946 kg)
Wheel Base	49 in (1244 mm)



SERVICE CAPACITIES

Fuel Tank	30 gal (113 L)
Hydraulic Tank	10 gal (38 L)
Engine Coolant/Antifreeze	3 gal (11 L)
Engine Oil (including filter)	9 quarts (8.52 L)

AUXILIARY HYDRAULIC SYSTEM

System Pressure, maximum	3335 psi (230 bar)
Controls	Pilot hydraulic joystick
Couplers	3/4" Flat Faced
Auxiliary Pump Flow	21.5 gpm (81 lpm)

ELECTRICAL SYSTEM

Normal Charge	12V
Battery	925 CCA
Charging System	90 Amp Alternator
Outlets	1-12V Port Inside Operator Station

OPERATOR STATION

Seat: Standard seat with an optional adjustable suspension seat available.	
Loader Control: Right-hand pilot hydraulic joystick controls loader lift/tilt, with intermittent control of auxiliary hydraulics.	
Drive Control: Left-hand pilot hydraulic joystick controls machine speed and direction.	
Engine speed control	Foot Throttle
Indicators/ Gauges	Fuel Tachometer Engine Temperature Hour Meter Battery Two-Speed Oil Level Hydraulic Temperature Water Temperature
ROPS/FOPS	Meets ISO 3471:2008 ISO 6683:2005 ISO 3449:2005 Level 1
Illumination	2 Forward Facing Lights 2 Rear Facing Lights



DIMENSIONS: GENERAL PURPOSE BUCKET

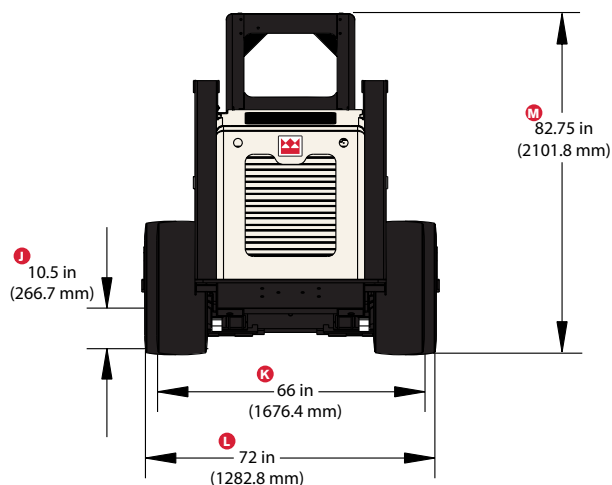
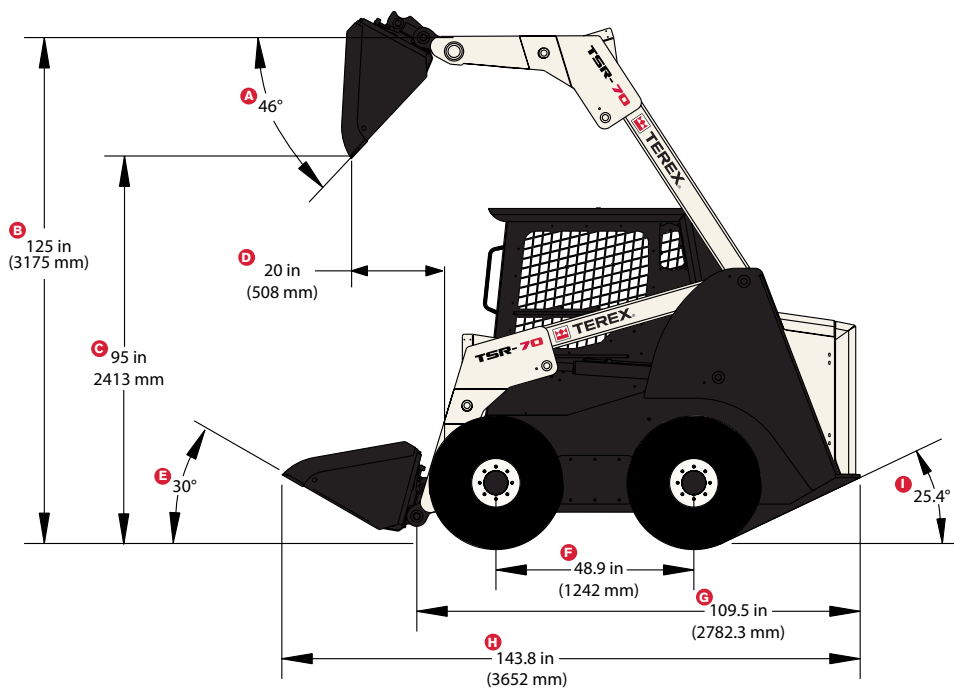

MEASUREMENTS

A	Dump Angle	H	Overall Length with Bucket
B	Height to Hinge Pin	I	Rear Angle of Departure
C	Height to Bucket Discharge	J	Unloaded Ground Clearance [10 in (254 mm) Loaded]
D	Reach at Full Height	K	Width Between Tires with Rims Reversed
E	Bucket Rollback at Ground Level	L	Width Between Tires
F	Wheel Base	M	Overall Height to Top of ROPS
G	Overall Length without Bucket		

OPTIONAL EQUIPMENT

OPTIONAL ATTACHMENTS

Auger Drive And Bits	Brush Cutter, Rotary	Snow Blade
Backhoe	Dozer Blade	Snow Blower
Broom, Rotary	Eliminator Rake	Stump Grinder
Bucket, General Purpose	Grapple Bucket	Trencher
Bucket, Light Material	Pallet Forks	Vibratory Roller
Bucket, Multi-Purpose	Power Box Rake	

Additional attachments available upon request.

www.terex.com

Effective Date: April 2011. Product specifications and prices are subject to change without notice or obligation. The photographs and/or drawings in this document are for illustrative purposes only. Refer to the appropriate Operator's Manual for instructions on the proper use of this equipment. Failure to follow the appropriate Operator's Manual when using our equipment or to otherwise act irresponsibly may result in serious injury or death. The only warranty applicable to our equipment is the standard written warranty applicable to the particular product and sale and Terex makes no other warranty, express or implied. Products and services listed may be trademarks, service marks, or trade names of Terex Corporation and/or its subsidiaries in the USA and other countries. All rights are reserved. Terex is a registered trademark of Terex Corporation in the USA and many other countries. © 2011 Terex Corporation.

Terex Construction 8800 Rostin Road, Southaven, MS 38671 USA
Tel +1 (888) 90-TEREX www.terex.com



WORKS FOR YOU.™

TSR70 0411 PN 280227